



**371007 (E7STGH1000)**  
Gas Solid Top

## Main Features

- All major compartments located in front of unit for ease of maintenance.
- Durable cast iron cooking plate, easy to clean.
- Central burner with optimized combustion, flame failure device and protected pilot light.
- Gas heated, 7 kW central burner, solid top.
- Pans can easily be moved from one area to another without lifting.
- Temperature gradients to satisfy different cooking needs, provided over the whole plate thanks to the temperature fine-tuning by zone.
- The center of the plate can reach a maximum temperature of 500 °C while decreasing outwards.
- Various sizes of pans can be used at the same time due to large surface area with no intermediate sectors.
- Suitable for countertop installation.

## Construction

- Model has right-angled side edges to allow flush fitting joints between units, eliminating gaps and possible dirt traps.
- One piece pressed 1.5 mm work top in Stainless steel.
- IPx4 water protection.
- All exterior panels in Stainless Steel with Scotch Brite finishing.



## Optional Accessories

PNC Code	Description
<b>Baskets</b>	
921020	2 baskets, left and right (105x160x240) for pasta cookers - 700XP and EMPower
<b>Bridge supports</b>	
206137	Support for bridge type installation, 800mm
206138	Support for bridge type installation, 1000mm
206139	Support for bridge type installation, 1200mm
206140	Support for bridge type installation, 1400mm
206141	Support for bridge type installation, 1600mm
<b>Burner grids, plates, supports</b>	
206363	Wok pan support for open burners (700/900)
<b>Chimney upstands</b>	
206133	Matching ring for flue condenser, 150 mm diameter
206246	Flue condenser for 1 module, 150 mm diameter
206304	Chimney upstand, 800mm
206400	Chimney grid net, 400mm (700XP/900)
<b>Gas nozzles</b>	
206461	Kit G.25.3 (NI) gas nozzles for 700 solid top and solid top combined with burners
<b>Handrails</b>	
206307	Right and left side handrails
216047	Frontal handrail, 800mm
216049	Frontal handrail, 1200mm
216050	Frontal handrail, 1600mm
216186	Large handrail - portioning shelf, 800mm
<b>Installation solutions</b>	
206086	Junction sealing kit
<b>Other accessories</b>	
927225	Pressure regulator for gas units
<b>Panels</b>	
216277	2 side covering panels for top appliances
<b>Water taps</b>	
206289	Water column with swivel arm (water column extension not included)
206291	Water column extension for 700 line
<b>Other accessories</b>	
206388	Kit town gas nozzles (G150) for 700 solid top and burner



# Technical specifications

## Gas

Gas Power:	7 kW
Standard gas delivery:	Natural Gas G20 (20mbar)
Gas Type Option:	LPG
Gas Inlet:	1/2"
<b>Key Information:</b>	
External dimensions, Width:	800 mm
External dimensions, Depth:	730 mm
External dimensions, Height:	250 mm
Net weight:	65 kg
Shipping weight (gross):	66 kg
Shipping height:	520 mm
Shipping width:	820 mm
Shipping depth:	860 mm
Shipping volume:	0.37 m <sup>3</sup>
Certification group:	N7TG
Solid top usable surface (width):	690 mm
Solid top usable surface (depth):	595 mm

## Front

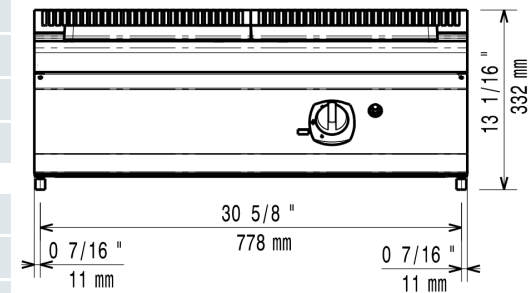

## Side

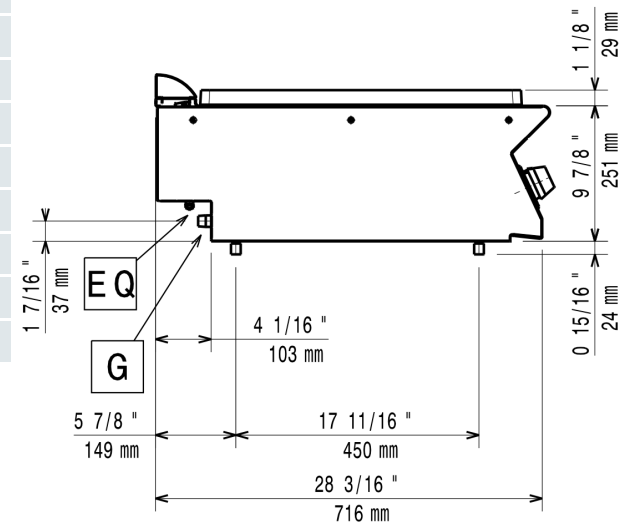

## Top

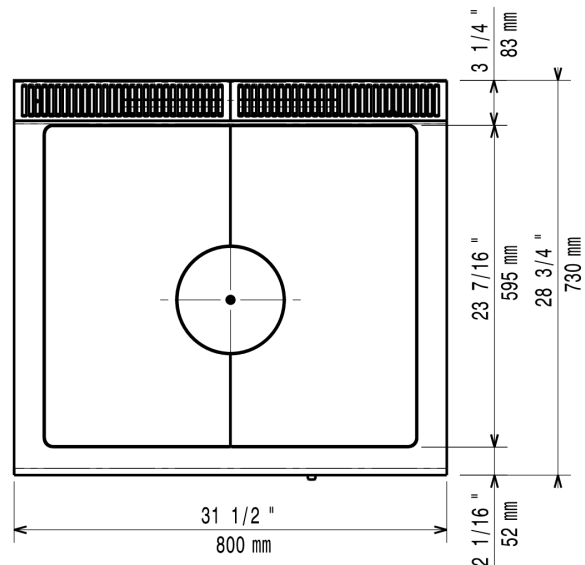

G = Gas connection  
EQ = Equipotential screw



Find out more:  
ISO Certificates  
Electrolux Professional Recognitions

The company reserves the right to make modifications to the products without prior notice. All information correct at time of printing.

2026/06/25

3/3